



CBRN/CO2/CO Air Filtration Systems

Atmas offers a wide selection of advanced, professional and certified systems and components related to air filtration and management, along with a variety of project support services for civil defense shelters, bunkers, saferooms, storage facilities and other applications.

- **CBRN Filtration Systems**
- **CO2 Scrubbers**
- **CO Scrubbers**
- **Special Filters**
- **Blast and Air Valves**
- **Components for Shelters**

SAFE 360 CBRN filtration and ventilation system is a compact, and certified solutions especially designed for safe rooms, residential shelters, small bunkers, containers and other protected spaces for providing fresh filtered from chemical, biological, radiological and nuclear materials air and creation of protected environment in the intended area.



Highlights

- Tested and certified for compliance to requirements of SI4570 standard
- Approved by Civil Defence Command
- Installed in tens of thousands of shelters
- Very cost-effective
- Ventilation/filtration modes – 54/36 m³/h
- Electricity: 100-240 VAC/12 VDC
- SAFE 360 kit includes blast valve, prefilter, electric blower, manual backup, CBRN filter, overpressure valve, air hoses and more.

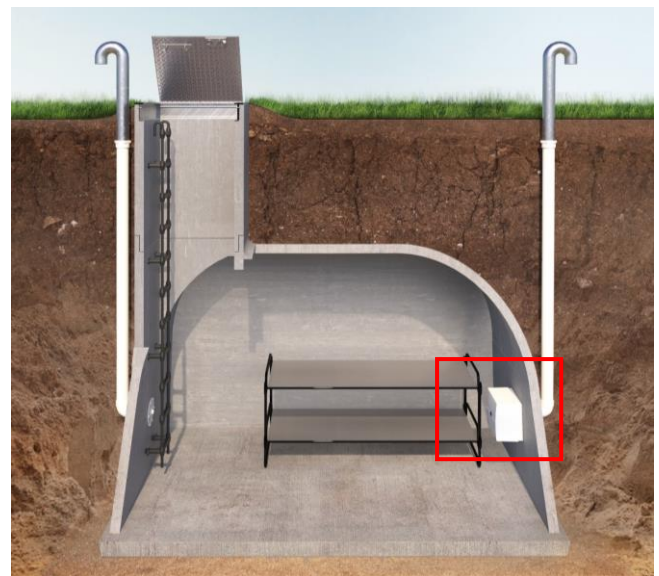

ARC type CBRN filtration and ventilation system are advanced, professional and certified CBRN (chemical, biological, radiological and nuclear) air filtration and ventilation systems designed for different sizes of protected spaces like shelters, bunkers, strategic facilities and other for providing fresh filtered air and creation of protected environment in the intended area.



System name	Airflow Filtration/Ventilation	Max. Shelter Volume (per system)
ARC 100	100/200 m3/h	100 m3
ARC 180	180/360 m3/h	180 m3
ARC 240	240/480 m3/h	240 m3
ARC300	300/600 m3/h	300 m3
ARC 450	450/900 m3/h	450 m3
ARC 600	600/1200 m3/h	600 m3
ARC 900	900/1800 m3/h	900 m3
ARC 1200	1200/2400 m3/h	1200 m3
ARC 1800	1800/3600 m3/h	1800 m3

* Several systems can be installed in one shelter

** ARC system kit includes blast valve, prefilter, electric blower, manual backup (optional), CBRN filter, overpressure valve/s, air hoses and more.

Filter Banks CBRN filtration systems are multifilter CBRN filtration systems specially designed to fit project requirements like allocated space, airflow, standards, control system, etc.). Each system can be integrated with up to 10 filters with different airflows (600, 900, 1200 or 1800 m³/h) creating one unit with high air volume which can be used in civil defence shelters, bunkers and protected spaces.

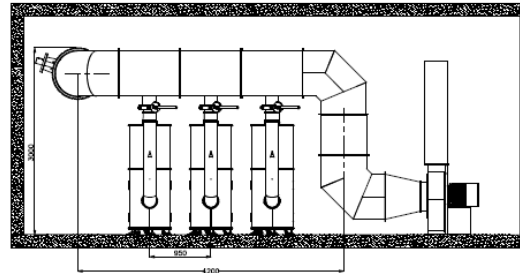
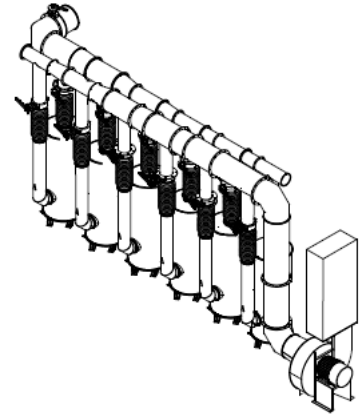
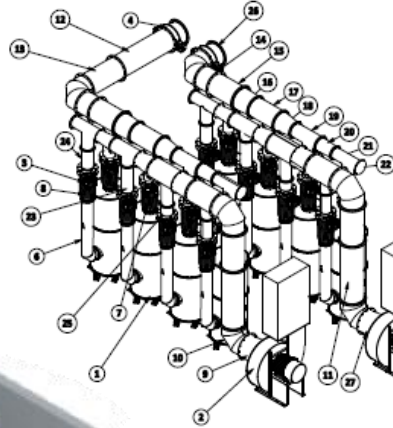
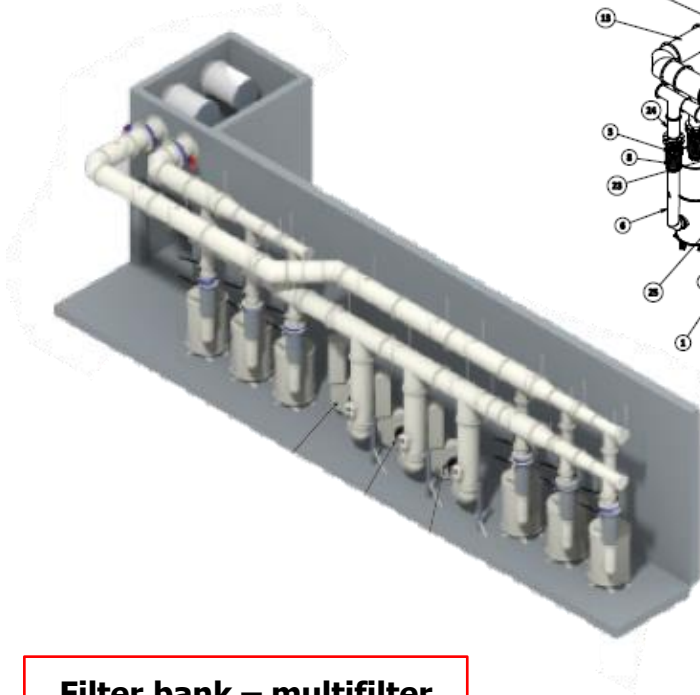

Filter bank – multifilter CBRN filtration unit



CO2/CO Scrubbers and O2/Air supply systems required for maintaining safe level of carbon dioxide (CO2), carbon monoxide (CO) and oxygen (O2) in isolated from external environment shelters, industrial facilities and spaces, as well as maintenance of overpressure inside the protected area.



Oxygen (O2) Supply & Overpressure Systems



CO2 scrubber

oxygen supply & overpressure systems



CO2/CO removal systems - scrubbers



Standard and custom designed CBRN, CO2 and CO filters for air filtration systems and air handling units (AHU).

**CBRN filters
(SI4579 standard)**



**Specially designed CBRN,
CO2 and CO filters.**

Blast valves (BVNO) – normally open valves which installed on ventilation openings or integrated into ventilation ducts to protect the system and internal space of shelters or facilities from sudden rise of pressure result of the blast.

Overpressure valves (BVNC) – normally closed valves which installed in airtight shelters to maintain overpressure levels by releasing the air.

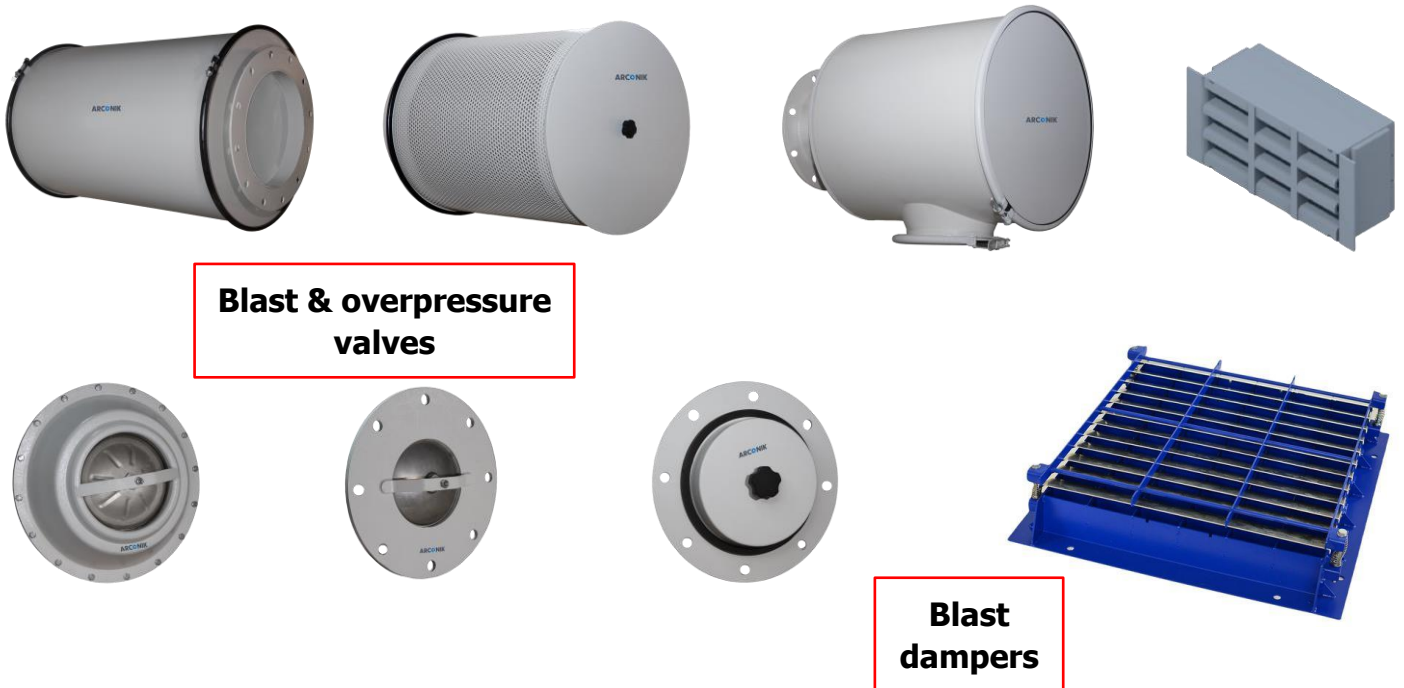

Gastight valves (GTV) – valves with manual or electric drive are intended for installation on ventilation duct for blocking the airflow.

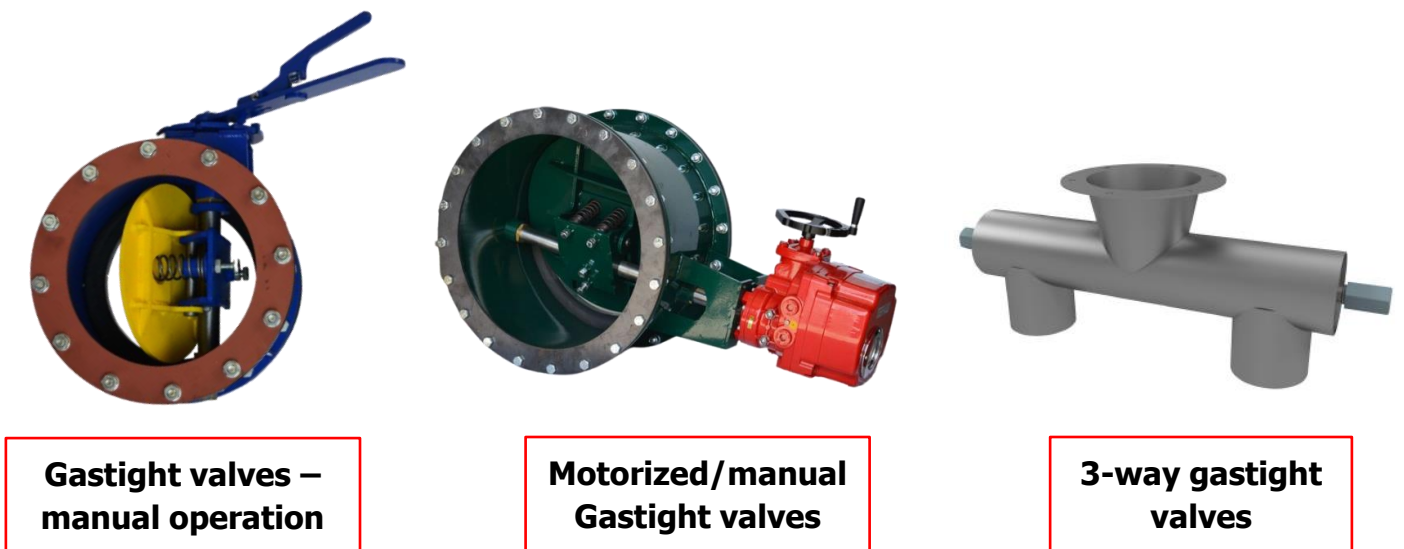

High- and low-pressure blowers for air filtration and ventilation systems with electric and manual operation function.

Shelter high pressure electric blower with silencer



Shelter high pressure electric blower with manual backup



Shelter low pressure ventilation electric blower with manual backup

SHELTERS



REINFORCEMENT

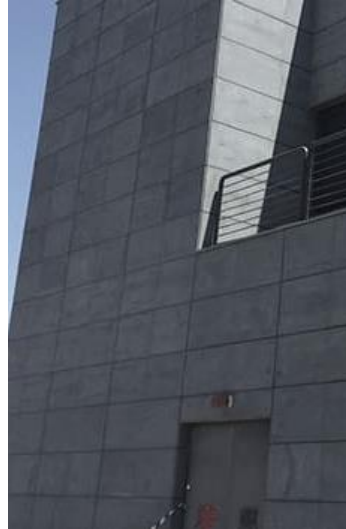

SECURITY



EMERGENCY



Atmas Group is a Finland based, global supplier of solutions for civil defense shelters and protected spaces, critical infrastructure and facilities reinforcement, CBRN, blast, ballistic, forced entry, fire, EMP protection, security structures, emergency response and more.

We offer a wide range of professional, certified and cost-effective products and project support services, through a global network of partners and distributors.

Visit our website: www.atmas-tech.com

Atmas Group Oy

Sturenkatu 26, 00510 Helsinki, Finland

Tel: +358 44 9843373

Email: info@atmas-tech.com

Web: www.atmas-tech.com